

# Kings Cross underground station, November 1987

- On 18 November 1987 a fire occurred at King's Cross, one of London's busiest underground stations and the most complex on the underground system, which engulfed the ticket hall and killed 31 people.
- Fire started under one of the old wooden escalators leading up to the ticket hall from the Piccadilly line and spread up to the ticket hall and then to the passageways leading from the ticket hall to the streets.

## In preparation



# The complex interconnections

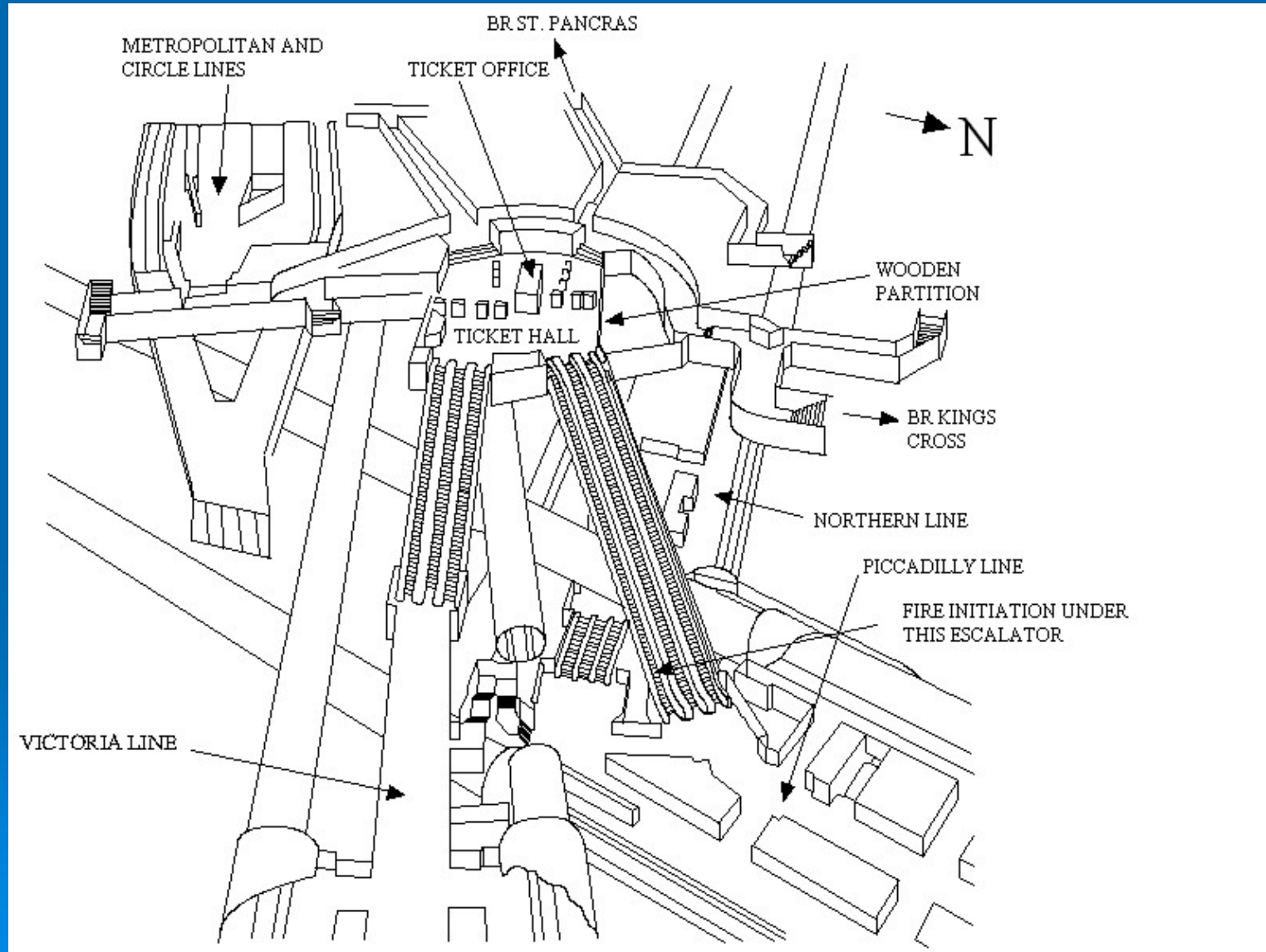

# The escalator design

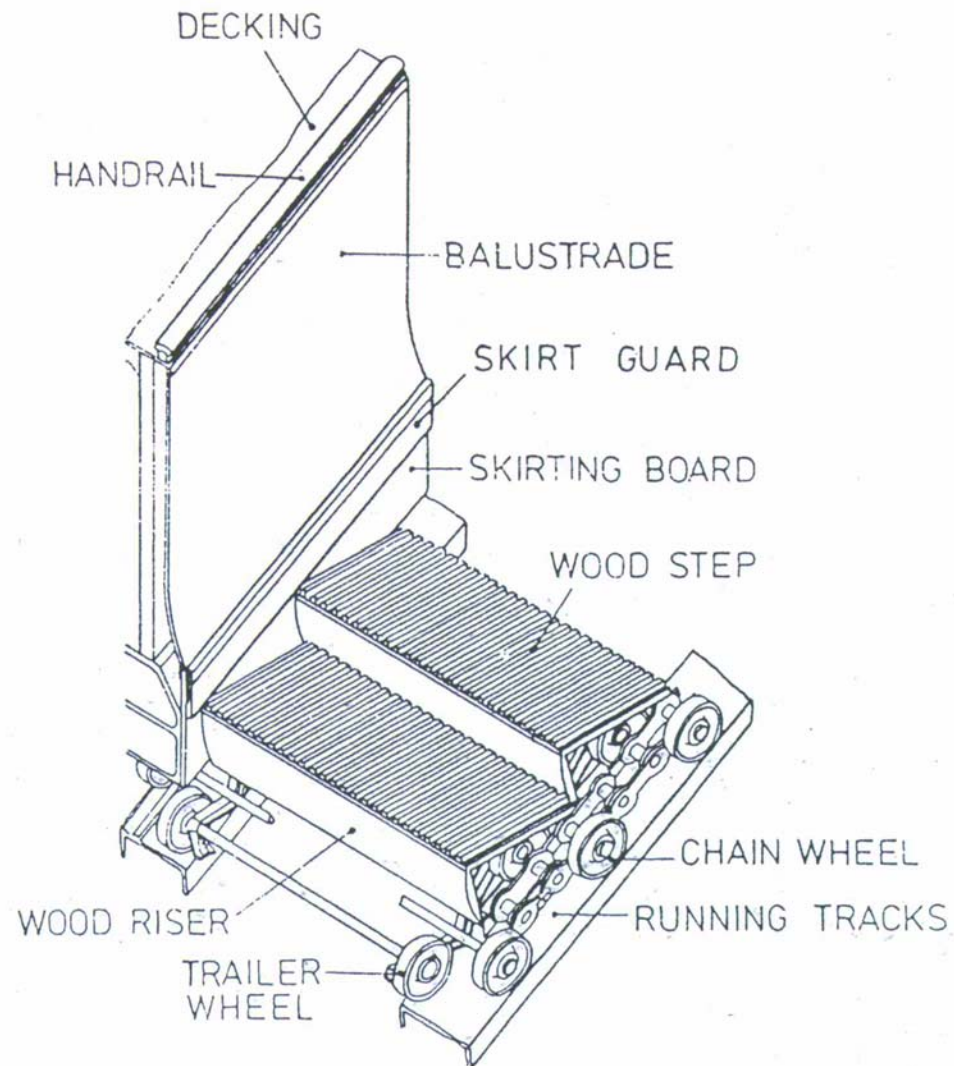

# Ticket hall at top of escalators after fire



# The trench fire effect

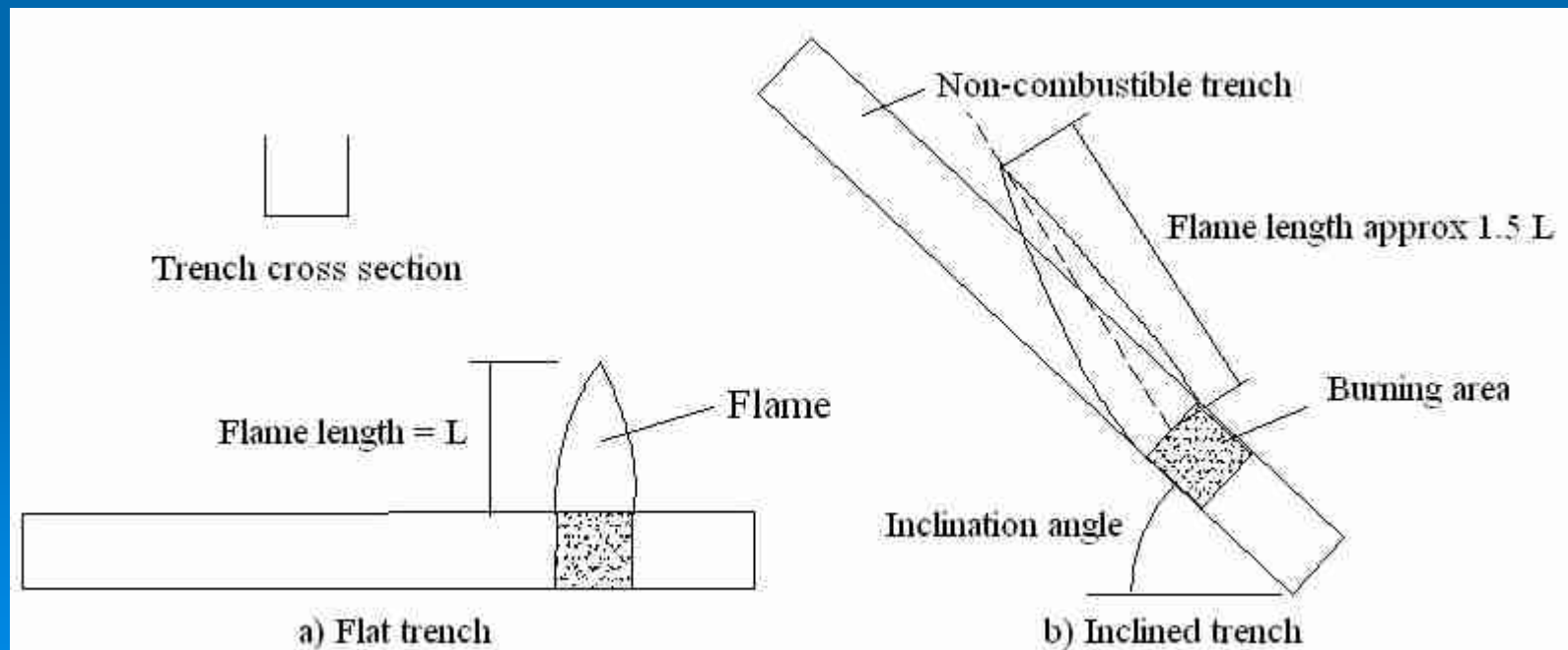

# Flame route in escalator and ticket hall – the hypothesis

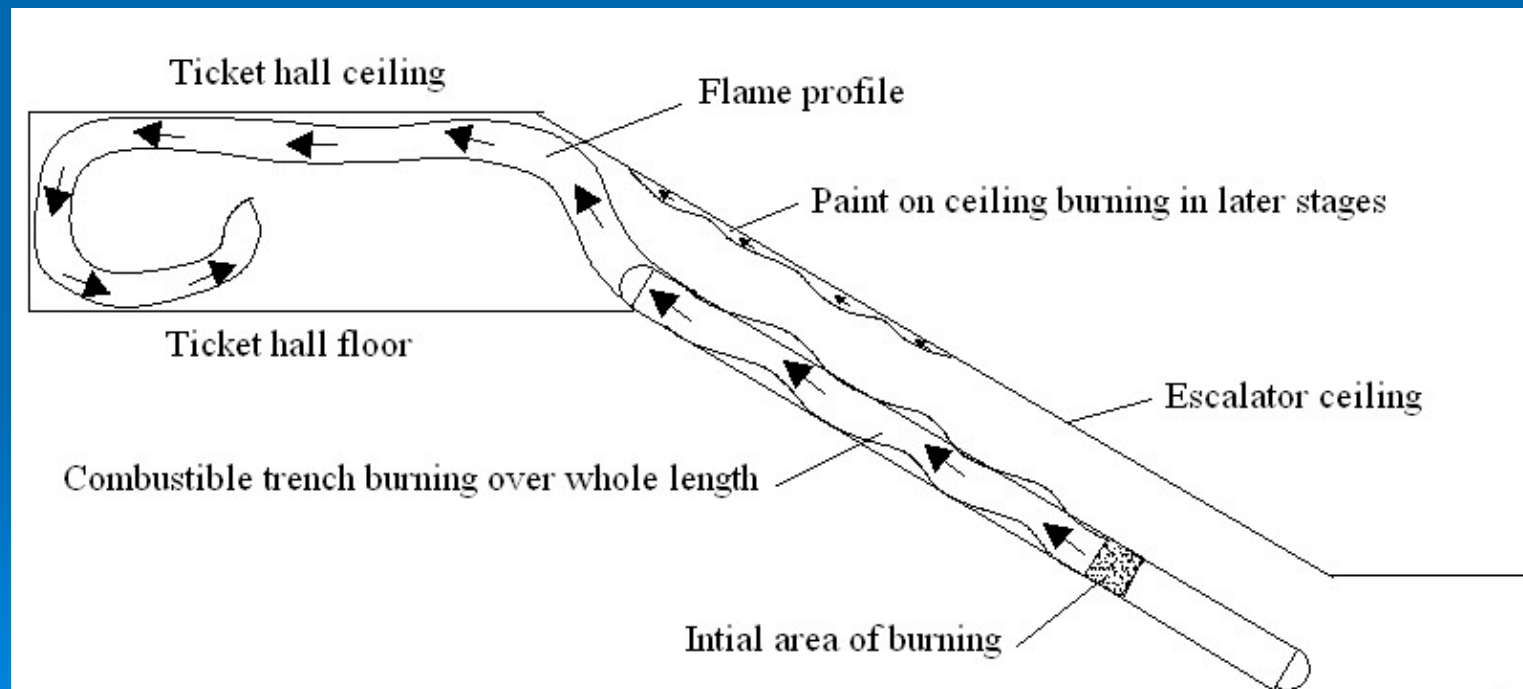

# Escalator ceiling paint burnt away

